

WATER COOLED FIXED BUNDLE/A SERIES

ITT INTERCHANGE
COMPETITIVELY PRICED

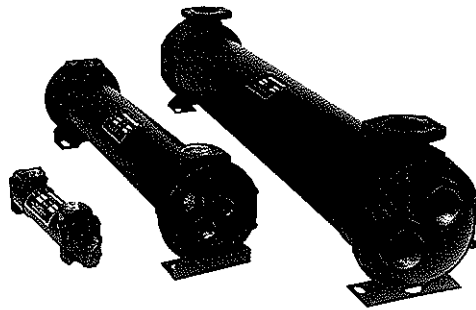

- Optional Non-Ferrous Construction (Water-to-Water Service)
- Optional 90/10 Copper Nickel Cooling Tubes and Bronze End Bonnets for Sea Water Service
- NPT, SAE O-Ring, SAE Flange, or BSPP Shell Side Connections Available
- End Bonnets Removable for Servicing
- Mounting Feet Included (May be Rotated in 90° Increments)

A/SA/SSA

water cooled

MATERIALS

Tubes - Copper
Hubs & Tubesheets - Steel
Shell - Steel
Baffles - Brass

End Bonnets - Cast Iron
Mounting Brackets - Steel
Gaskets - Nitrate RUBber/Cellulose Fiber
Nameplate - Aluminum Foil

RATINGS

STANDARD
Maximum shell pressure - 300 psi
Maximum tube side pressure - 150 psi
Maximum temperature - 300°F

HOW TO ORDER

MODEL SERIES	MODEL SIZE SELECTED	BAFFLE SPACING	TUBE DIAMETER CODE	TUBESIDE PASSES	SHELL MATERIAL	COOLING TUBE MATERIAL	END BONNET MATERIAL	ZINC ANODES
SA A				O - ONE PASS	BLANK - STEEL	BLANK - COPPER	BLANK - CAST IRON	BLANK - NONE
SAS AS				T - TWO PASS	BR - BRASS	CN - CU-NI	B - BRONZE	Z - ZINC ANODES
AM				F - FOUR PASS				
AF								
AFM								

STEEL SHELL

SA = NPT Shell side, NPT Tube
SAS = SAE O-Ring, NPT Tube

A = NPT Shell side connections; NPT Tube side connections
AS = SAE O-Ring Shell side connections; NPT Tube side connections
AM = BSPP Shell side connections; BSPP Tube side connections
AF = SAE 4 Bolt Flange (with UNC threads) Shell side connections; NPT Tube side connections
AFM = SAE 4 Bolt Flange (with Metric threads) Shell side connections; BSPP Tube side connections
SAE flanges available on some models. Consult factory for details.

PERFORMANCE CURVES & WEIGHTS

MODEL CODE	SHP. WT. (LBS.)	25: A-1236-3-6-F	118
1: A-408-2-4-O	7	26: A-1248-3-6-F	143
2: A-408-75-4-O	7	27: A-1260-4-6-F	165
3: A-608-2-4-F	12	28: A-1624-6-6-F	180
4: A-614-4-4-F	17	29: A-1636-6-6-F	210
5: A-624-4-4-F	20	30: A-1648-6-6-F	250
6: A-608-1-4-F	12	31: A-1660-6-6-F	286
7: A-614-1.5-4-F	17	32: A-1672-6-6-F	330
8: A-624-2-4-F	20	33: A-1624-2-6-F	180
9: A-814-3-4-F	40	34: A-1636-3-6-F	210
10: A-824-4-4-F	50	35: A-1648-3-6-F	250
11: A-836-4-4-F	58	36: A-1660-4-6-F	286
12: A-814-1.5-4-F	40	37: A-1672-4-6-F	330
13: A-824-2-4-F	50		
14: A-836-2-4-F	58		
15: A-1014-3-6-F	49		
16: A-1024-4-6-F	63		
17: A-1036-4-6-F	72		
18: A-1024-2-6-F	63		
19: A-1036-2-6-F	72		
20: A-1224-4-6-F	78		
21: A-1236-6-6-F	118		
22: A-1248-6-6-F	143		
23: A-1260-6-6-F	165		
24: A-1224-2-6-F	78		

*Shipping Weights are approximate

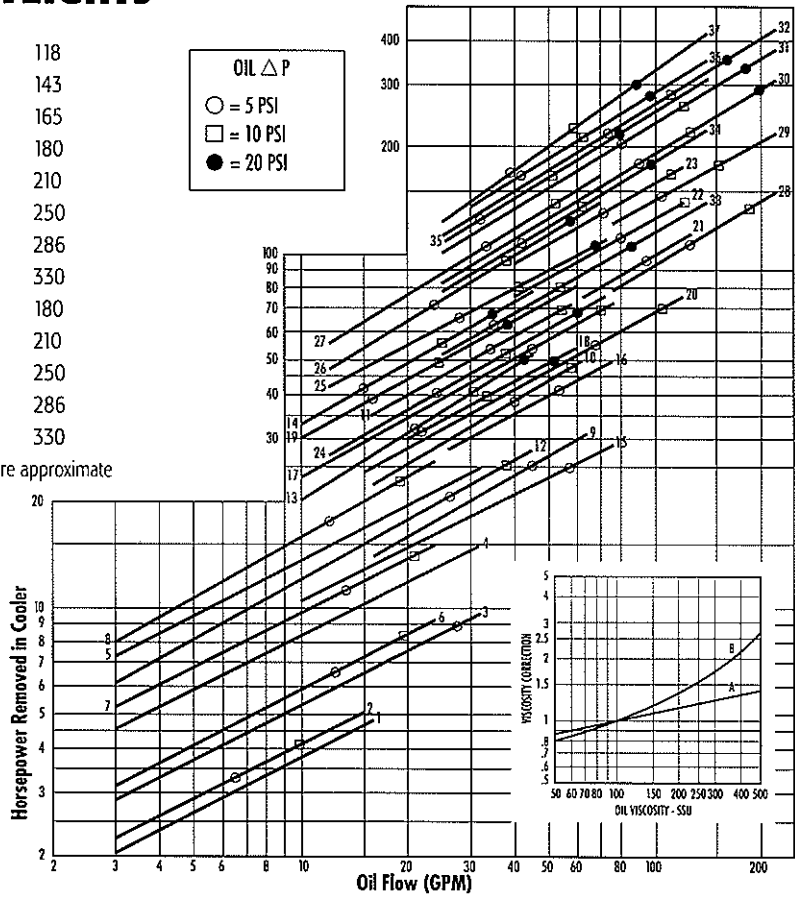

SELECTION PROCEDURE

Performance Curves are based on 100SSU oil leaving the cooler 40°F higher than the ambient air temperature used for cooling. This is also referred to as a 40°F approach temperature.

Step 1. Determine the Heat Load.

This will vary with different systems, but typically coolers are sized to remove 25 to 50% of the input nameplate horsepower. (Example: 100 HP Power Unit x .33 = 33 HP Heat load.)

$$\text{If BTU/Hr. is known: } HP = \frac{\text{BTU/Hr}}{2545}$$

Step 2. Determine Approach Temperature.

Desired oil leaving cooler °F - Water Inlet temp. °F = Actual Approach (Max. reservoir temp.)

Step 3. Determine Curve Horsepower Heat Load.

Enter the information from above:

$$\text{Horsepower heat load} \times \frac{40}{\text{Actual Approach}} \times \text{Viscosity Correction A} = \text{Curve Horsepower}$$

Step 4. Enter curves at oil flow through cooler and curve horsepower.

Any curve above the intersecting point will work.

Step 5. Determine Oil Pressure Drop from Curves:

○ = 5 PSI; □ = 10 PSI; ● = 20 PSI. Multiply pressure drop from curve by correction factor B found on oil viscosity correction curve.

Oil Temperature: Oil coolers can be selected using *entering* or *leaving* oil temperatures.

Typical operating temperature ranges are:

Hydraulic Oil: 110°F - 130°F, Hydrostatic Drive Oil: 130°F - 180°F,

Bearing Lube Oil: 120°F - 160°F, Lube Oil Circuits: 110°F - 130°F.

Desired Reservoir Temperature

Return Line Cooling: Desired temperature is the oil temperature leaving the cooler. This will be the same temperature that will be found in the reservoir.

Off-Line Recirculation Cooling Loop: Desired temperature is the oil temperature *entering* the cooler. In this case, the oil temperature change

must be determined so that the actual oil leaving temperature can be found. Calculate the oil temperature change (oil ΔT) with this formula:
Oil $\Delta T = (\text{BTU's/Hr.}) / (\text{GPM Oil Flow} \times 210)$.

To calculate the oil leaving temperature from the cooler, use this formula:
Oil Leaving Temp. = Oil Entering Temp - Oil ΔT .

This formula may also be used in any application where the only temperature available is the entering oil temperature.

Oil Pressure Drop: Most systems can tolerate a pressure drop through the heat exchanger of 20 to 30 PSI. Excessive pressure drop should be avoided. Care should be taken to limit pressure drop to 5 PSI or less for case drain applications where high back pressure may damage the pump shaft seals.

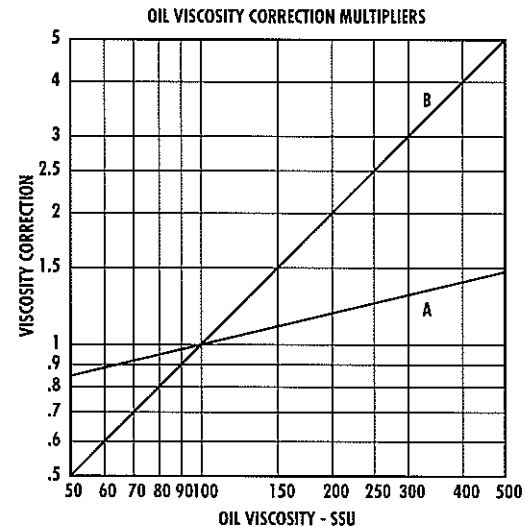

water cooled

A/SA/SSA

STANDARD MODELS & DIMENSIONS

ONE PASS

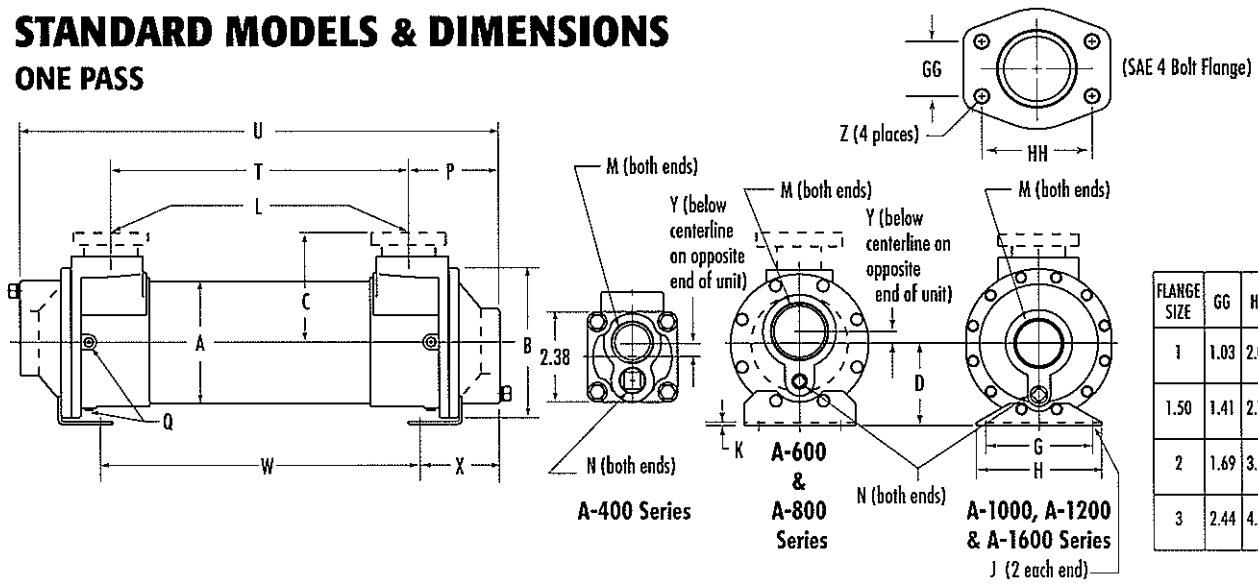

FLANGE SIZE	GG	HH	Z AF	Z AFM
1	1.03	2.06	3/8-16 UNC	M-10
1.50	1.41	2.75	1/2-13 UNC	M-12
2	1.69	3.06		
3	2.44	4.19	5/8-11 UNC	M-16

MODEL	A DIA.	B DIA.	C		D	G	H	J	K	L		M NPT	N NPT	P	Q NPT	T	U	W	X	Y
			NPT/BSPP SAE O-RING	SAE 4 BOLT FLANGE						NPT/BSPP FLANGE	SAE O-RING									
A-408	2.12	—	1.69	—	—	—	—	—	—	*1.00	N/A	.75	—	2.38	—	6.25	11.00	—	—	—
A-608	3.12	4.19	2.44	C/F	2.44	2.50	3.50	.38 x .88	.12	1.00	#16, 1 1/16-12 UNF-28	1.50	.38	2.56	(2) .25	6.12	11.25	5.47	3.06	.38
A-614																12.12	17.25	11.47		
A-624																22.12	27.25	21.47		
A-814																11.12	18.00	12.88		
A-824	4.12	5.88	3.12	C/F	3.50	4.75	.50 x 1.62	.12	1.50	#24, 1 7/8-12 UN-28	2.00	.38	3.44	(6) .38	21.12	28.00	22.88	2.56	.50	
A-836															33.12	40.00	34.88			
A-1014	5.12	6.50	3.62	4.34	4.00	5.00	.50 x .88	.12	1.50	#32, 2 1/2-12 UN-28	2.50	.50	3.69	—	11.12	18.50	11.75	3.38	—	
A-1024															21.12	28.50	21.75			
A-1036															33.12	40.50	33.75			
A-1224															20.50	29.00	21.50			
A-1236	6.12	7.50	4.25	4.84	4.12	5.00	6.00	.12	2.00	#32, 2 1/2-12 UN-28	3.00	.50	4.25	(6) .25	32.50	41.00	33.50	3.75	—	
A-1248															44.50	53.00	45.50			
A-1260															56.50	65.00	57.50			
A-1624	8.00	9.75	5.62	6.12	5.38	7.00	8.25	.62 x 1.12	.19	3.00	—	.50	6.00	—	19.00	31.00	20.50	5.25	—	
A-1636															31.00	43.00	32.50			
A-1648															43.00	55.00	44.50			
A-1660															55.00	67.00	56.50			
A-1672	—	—	—	—	—	—	—	—	—	—	—	—	—	—	67.00	79.00	68.50	—	—	

* A-408 SAE Flange Not Available. All dimensions in inches. NOTE: We reserve the right to make reasonable design changes without notice.

A/SA/SSA

water cooled

STANDARD MODELS & DIMENSIONS

TWO PASS

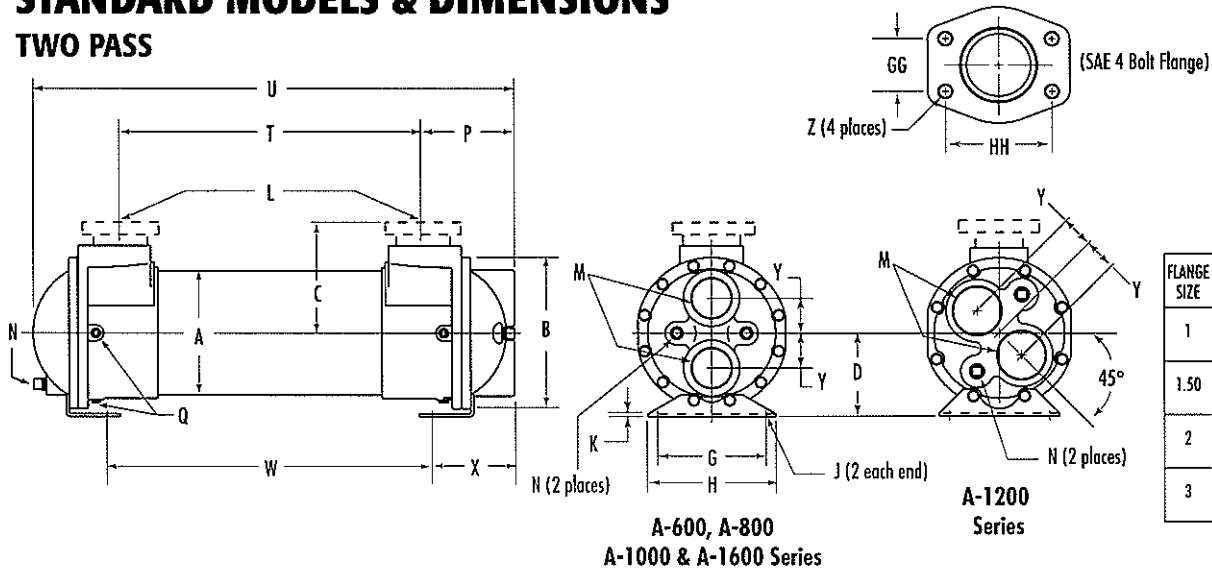

MODEL	A DIA.	B DIA.	C		D	G	H	J	K	L		M NPT	N NPT	P	Q NPT	T	U	W	X	Y			
			NPT/BSPP SAE O-RING	SAE 4 BOLT FLANGE						NPT/BSPP FLANGE	SAE O-RING												
A-608																6.12	10.75	5.47					
A-614	3.12	4.19	2.44	C/F	2.44	2.50	3.50	.38 x .88	.12	1.00	#16, 1 3/16-12 UNF-2B	1.00	.38	2.44	(2) .25	12.12	16.75	11.47	2.94	1.00			
A-624																			22.12	26.75	21.47		
A-814																			11.12	17.62	12.88		
A-824	4.12	5.88	3.12				3.50	4.75		.50 x 1.62		1.25		#24, 1 7/8-12 UN-2B	1.25		3.44	(6) .38	21.12	27.62	22.88	2.56	1.19
A-836					3.50												33.12	39.62	34.88				
A-1014																	11.12	18.31	11.75				
A-1024	5.12	6.50	3.62	4.34		4.00	5.00			1.50		1.50			3.69		21.12	28.31	21.75	3.38	1.50		
A-1036								.50 x .88								33.12	40.31	33.75					
A-1224																20.50	28.75	21.50					
A-1236																32.50	40.75	33.50					
A-1248	6.12	7.50	4.25	4.84	4.12	5.00	6.00			2.00	#32, 2 1/2-12 UN-2B	2.00		4.25	(6) .25	44.50	52.75	45.50	3.75	1.56			
A-1260																56.50	64.75	57.50					
A-1624													.50			19.00	30.50	20.50					
A-1636																31.00	42.50	32.50					
A-1648	8.00	9.75	5.62	6.12	5.38	7.00	8.25	.62 x 1.12	.19	3.00	—	2.50		6.00		43.00	54.50	44.50	5.25	2.25			
A-1660																55.00	66.50	56.50					
A-1672																67.00	78.50	68.50					

All dimensions in inches. NOTE: We reserve the right to make reasonable design changes without notice.

water cooled

A/SA/SSA

STANDARD MODELS & DIMENSIONS

FOUR PASS

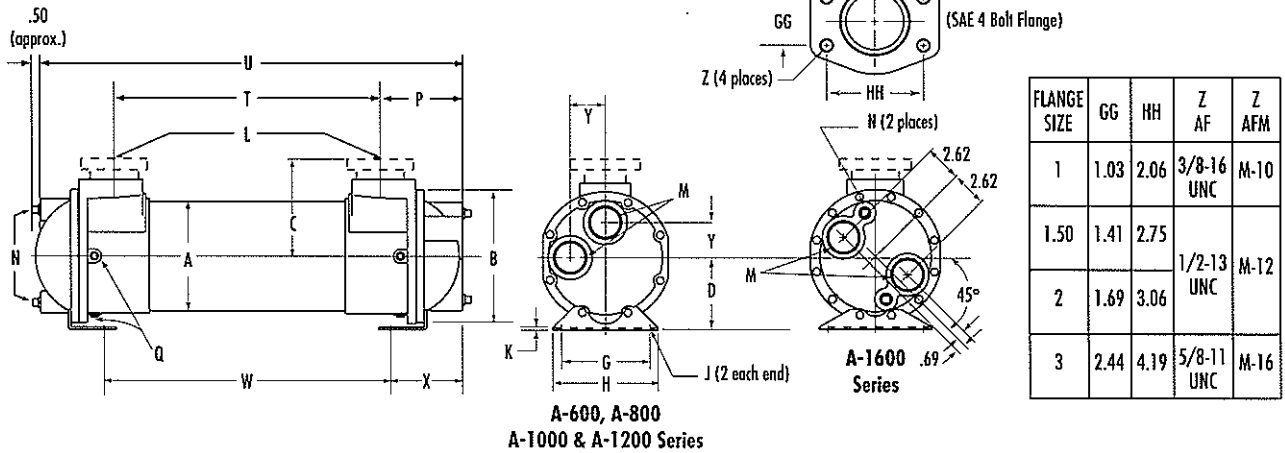

MODEL	A DIA.	B DIA.	C		D	G	H	J	K	L		M HPT	N HPT	P	Q HPT	T	U	W	X	Y
			NPT/BSPP SAE O-RING	SAE 4 BOLT FLANGE						NPT/BSPP FLANGE	SAE O-RING									
A-608	3.12	4.19	2.44	C/F	2.44	2.50	3.50	.38 x .88	.12	1.00	#16, 1 7/16-12 UNF-2B	.75	.38	2.31	(2) .25	6.12	10.88	5.47	2.81	1.00
A-614																12.12	16.88	11.47		
A-624																22.12	26.88	21.47		
A-814	4.12	5.88	3.12	C/F	3.50	4.75	.50 x 1.62	.12	1.50	#24, 1 7/8-12 UN-2B	1.00	.38	3.44	(6) .38	11.12	17.62	12.88	2.56	1.06	
A-824															21.12	27.62	22.88			
A-836															33.12	39.62	34.88			
A-1014	5.12	6.50	3.62	4.34	4.00	5.00	.50 x .88	.12	2.00	#32, 2 1/2-12 UN-2B	1.50	.50	4.25	(6) .25	11.12	18.38	11.75	3.25	1.69	
A-1024															21.12	28.38	21.75			
A-1036															33.12	40.38	33.75			
A-1224	6.12	7.50	4.25	4.84	4.12	5.00	6.00	.19	3.00	—	2.00	.50	6.00	—	20.50	29.00	21.50	5.25	—	
A-1236															32.50	41.00	33.50			
A-1248															44.50	53.00	45.50			
A-1260	8.00	9.75	5.62	6.12	5.38	7.00	8.25	.62 x 1.12	.19	3.00	—	2.00	6.00	—	56.50	65.00	57.50			
A-1624															19.00	30.75	20.50			
A-1636															31.00	42.75	32.50			
A-1648	8.00	9.75	5.62	6.12	5.38	7.00	8.25	.62 x 1.12	.19	3.00	—	2.00	6.00	—	43.00	54.75	44.50	5.25	—	
A-1660															55.00	66.75	56.50			
A-1672															67.00	78.75	68.50			

All dimensions in inches. NOTE: We reserve the right to make reasonable design changes without notice.

MAXIMUM FLOW RATES

Caution: Incorrect installation can cause this product to fail prematurely, causing the shell-side and tube-side fluids to intermix. Maximum allowable rates are as charted below.

Model No. Example: A - 1024 - 2 - 6 - F

Unit Size	Baffle Spacing	Shell Side (GPM)	Tube Side (GPM)		
			O	T	F
400	.75, 2	7, 19	18	—	—
600	1, 1.5, 2, 4	14, 21, 29, 29	48	24	12
800	1.5, 2, 3, 4	29, 38, 57, 69	87	43	21
1000			146	73	37
1200	2, 3, 4, 6	51, 77, 103, 115	224	112	56
1600			66, 100, 133, 200	280	203

PIPING HOOK-UP

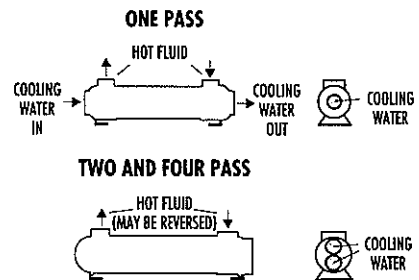

Specific applications may have different piping arrangements. Contact factory for assistance.

A/SA/SSA
water cooled

WATER COOLED STAINLESS STEEL/SSA SERIES

TYPE 316 STAINLESS STEEL
CONSTRUCTION

CUSTOM DESIGNS AVAILABLE

COMPETITIVELY PRICED

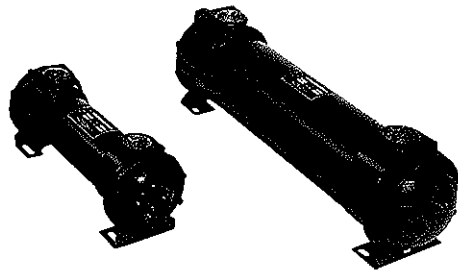

- Mounting Feet Included (May be Rotated in 90° increments)
- End Bonnets Removable for Servicing

water cooled
A/SA/SSA

MATERIALS

Tubes - 316 Stainless Steel
Hubs & Tubesheets - 316 Stainless Steel
Shell - 316 Stainless Steel
Baffles - 316 Stainless Steel

End Bonnets - 316 Stainless Steel
Mounting Brackets - Steel
Gaskets - Nitrate RUBber/Cellulose Fiber
Nameplate - Aluminum Foil

RATINGS

STANDARD
Maximum shell pressure - 225 psi
Maximum tube side pressure - 150 psi
Maximum temperature - 450°F

HOW TO ORDER

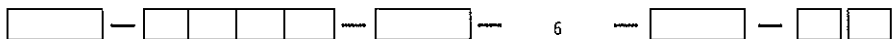

SSA

MODEL SIZE
SELECTED

BAFFLE
SPACING

TUBE DIAMETER

6

TUBESIDE
PASSES

END BONNET
MATERIAL

O - ONE PASS BLANK - STAINLESS STEEL
 T - TWO PASS CI - CAST IRON
 F - FOUR PASS

STANDARD MODELS & DIMENSIONS

ONE PASS

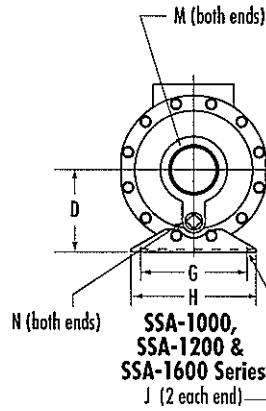
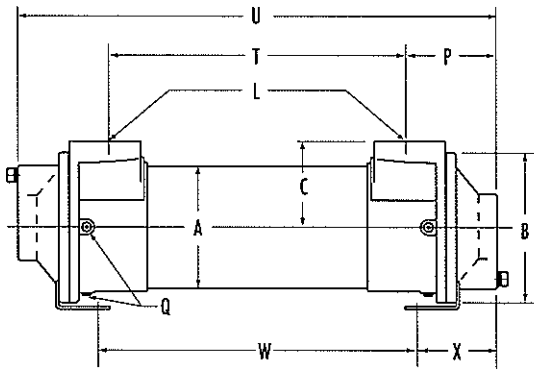

MODEL	A DIA.	B DIA.	C	D	G	H	J	K	L NPT	M NPT	N NPT	P	Q NPT	T	U	W	X	Y
SSA-1014	5.12	6.50	3.62	3.50	4.00	5.00	.50 x .88	.12	1.50	2.50	.38	3.69	(6) .25	11.12	18.50	11.75	3.38	---
SSA-1024														21.12	28.50	21.75		
SSA-1036														33.12	40.50	33.75		
SSA-1224	6.12	7.50	4.25	4.12	5.00	6.00			2.00			4.25	(6) .25	20.50	29.00	21.50	3.75	---
SSA-1236														32.50	41.00	33.50		
SSA-1248														44.50	53.00	45.50		
SSA-1260														56.50	65.00	57.50		
SSA-1624	8.00	9.75	5.62	5.38	7.00	8.25	.62 x 1.12	.19	3.00	3.00	.50	6.00	(6) .25	19.00	31.00	20.50	5.25	---
SSA-1636														31.00	43.00	32.50		
SSA-1648														43.00	55.00	44.50		
SSA-1660														55.00	67.00	56.50		
SSA-1672														67.00	79.00	68.50		
SSA-1684														79.00	91.00	80.50		
SSA-1696	91.00	103.00	92.50															

All dimensions in inches. NOTE: We reserve the right to make reasonable design changes without notice.

A/SA/SSA
water cooled

STANDARD MODELS & DIMENSIONS

TWO PASS

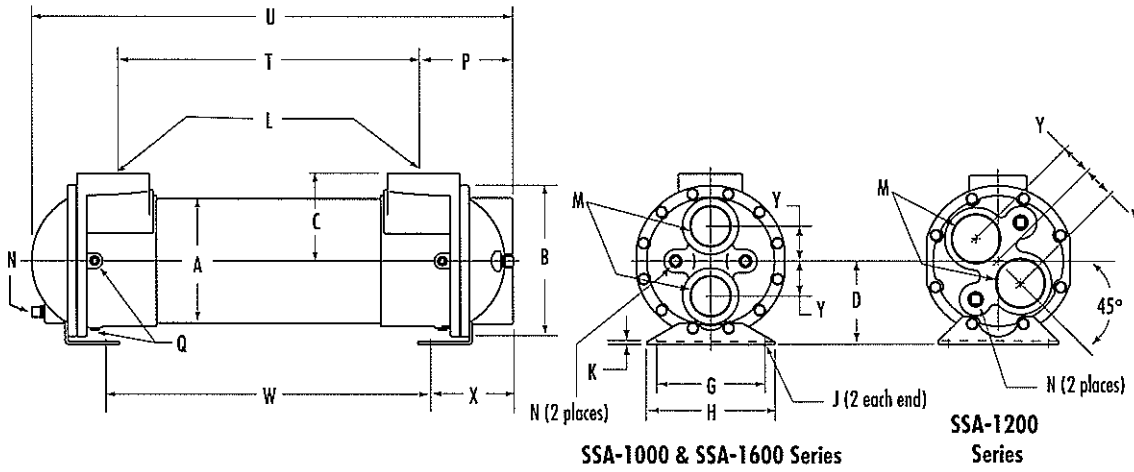

SSA-1000 & SSA-1600 Series

SSA-1200 Series

MODEL	A DIA.	B DIA.	C	D	G	H	J	K	L NPT	M NPT	N NPT	P	Q NPT	T	U	W	X	Y
SSA-1014	5.12	6.50	3.62	3.50	4.00	5.00			1.50	1.50	.38	3.69		11.12	18.31	11.75	3.38	1.50
SSA-1024														21.12	28.31	21.75		
SSA-1036														33.12	40.31	33.75		
SSA-1224	6.12	7.50	4.25	4.12	5.00	6.00	.50 x .88	.12	2.00	2.00		4.25	(6) .25	20.50	28.75	21.50	3.75	1.56
SSA-1236														32.50	40.75	33.50		
SSA-1248														44.50	52.75	45.50		
SSA-1260														56.50	64.75	57.50		
SSA-1624	8.00	9.75	5.62	5.38	7.00	8.25	.62 x 1.12	.19	3.00	2.50		6.00		19.00	30.50	20.50	5.25	2.25
SSA-1636														31.00	42.50	32.50		
SSA-1648														43.00	54.50	44.50		
SSA-1660														55.00	66.50	56.50		
SSA-1672														67.00	78.50	68.50		
SSA-1684														79.00	90.50	80.50		
SSA-1696	91.00	102.50	92.50															

water cooled

A/SA/SSA

STANDARD MODELS & DIMENSIONS

FOUR PASS

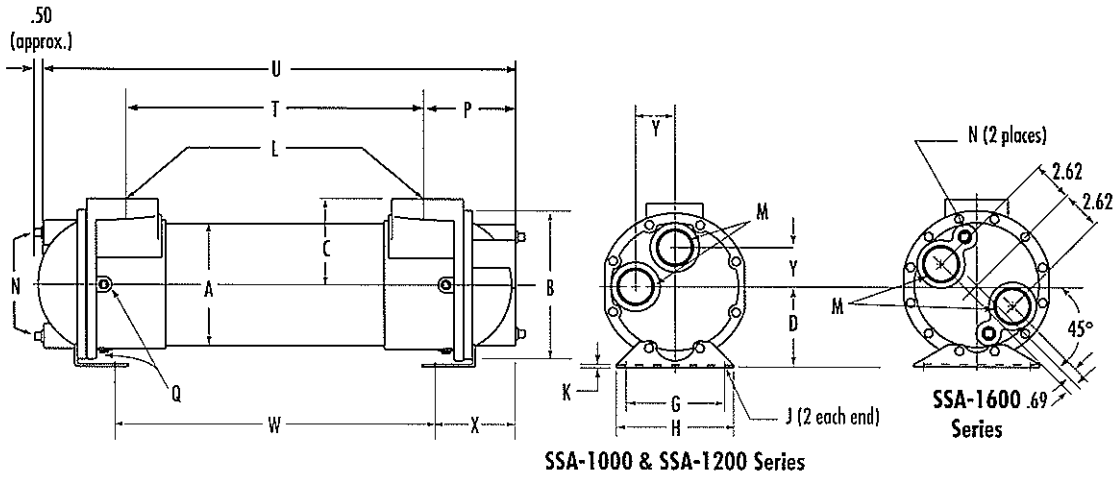

MODEL	A DIA.	B DIA.	C	D	G	H	J	K	L NPT	M NPT	N NPT	P	Q NPT	T	U	W	X	Y
SSA-1014														11.12	18.38	11.75		
SSA-1024	5.12	6.50	3.62	3.50	4.00	5.00			1.50	1.00	.38	3.56		21.12	28.38	21.75	3.25	1.69
SSA-1036														33.12	40.38	33.75		
SSA-1224							.50 x .88	.12						20.50	29.00	21.50		
SSA-1236									2.00	1.50		4.25	(6) .25	32.50	41.00	33.50		
SSA-1248	6.12	7.50	4.25	4.12	5.00	6.00								44.50	53.00	45.50	3.75	2.00
SSA-1260											.50			56.50	65.00	57.50		
SSA-1624														19.00	30.75	20.50		
SSA-1636														31.00	42.75	32.50		
SSA-1648	8.00	9.75	5.62	5.38	7.00	8.25	.62 x 1.12	.19	3.00	2.00		6.00		43.00	54.75	44.50	5.25	—
SSA-1660														55.00	66.75	56.50		
SSA-1672														67.00	78.75	68.50		
SSA-1684														79.00	90.75	80.50		
SSA-1696														91.00	102.75	92.50		

A/SA/SSA
 water cooled

MODEL	SURFACE AREA FT. ²	TUBE COUNT	WEIGHT
	3/8" O.D. TUBES	3/8" O.D.	LBS.
SSA-1014	9.16	80	40
SSA-1024	15.70	80	60
SSA-1036	23.56	80	85
SSA-1224	23.56	120	80
SSA-1236	35.34	120	105
SSA-1248	47.12	120	130
SSA-1260	58.91	120	155
SSA-1624	41.23	210	160
SSA-1636	61.85	210	200
SSA-1648	82.47	210	240
SSA-1660	103.08	210	280
SSA-1672	123.70	210	320
SSA-1684	144.31	210	360
SSA-1696	164.93	210	400

BAFFLE SPACING

Model

SSA-1014	1.5 & 3
SSA-1024	2 & 4
SSA-1036	2 & 4
SSA-1224	2 & 4
SSA-1236	3 & 6
SSA-1248	3 & 6
SSA-1260	4 & 6

Model

SSA-1624	2 & 6
SSA-1636	3 & 6
SSA-1648	3 & 6
SSA-1660	4 & 6
SSA-1672	4 & 6
SSA-1684	4 & 6
SSA-1696	4 & 6

MAXIMUM FLOW RATES

Caution: Incorrect installation can cause this product to fail prematurely, causing the shell-side and tube-side fluids to intermix. Maximum allowable rates are as charted below.

Model No. Example: SSA - 1024 - 2 - 6 - F

Unit Size	Baffle Spacing	Shell Side (GPM)	Tube Side (GPM)		
			O	T	F
1000	1.5, 2, 3, 4	32, 42, 64, 69	146	73	37
1200	2, 3, 4, 6	51, 77, 103, 115	224	112	56
1600		66, 100, 133, 200	280	203	101

For more information or to purchase these products, please contact:

HYDROTHRIFT CORPORATION
(800) 772-0493

www.hydrothrift.com
sales@hydrothrift.com

PIPING HOOK-UP

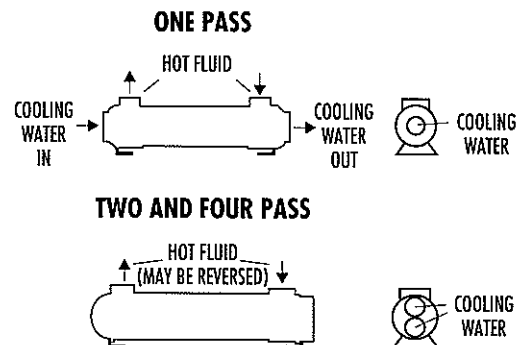

Specific applications may have different piping arrangements.
Contact factory for assistance.