

AIR COOLED COMPRESSED/UPA, AA, AHP SERIES

FULL LINE OF SIZES
AND FEATURES

ENERGY EFFICIENT

HIGH PERFORMANCE

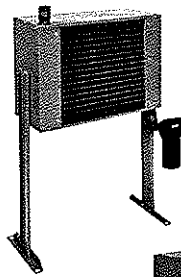

UPA SERIES

- Horizontal or Vertical Air Flow
- Lightweight, may be Shipped UPS
- Ratings Based on Comprehensive Testing
- Attractive, Durable Baked Enamel Finish
- Floor or Suspended Mounting
- Competitively Priced

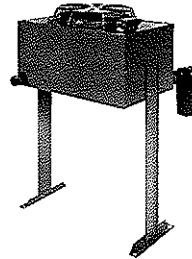

AHP SERIES

- Vertical Air Flow
- High Technology Compact Design
- Optional Air Motor
- Rugged Heavy Duty Construction
- Excellent for Heat Recovery

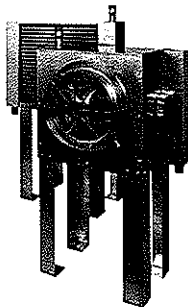

AA SERIES

- Horizontal Air Flow
- Optional Weatherproof Junction Box
- Floor or Suspended Mounting
- Optional TEFC motor(s)
- Ratings Based on Comprehensive Testing
- Wired for Single Point External Connection

air cooled
UPA/AA/AHP

MATERIALS

UPA SERIES

Cabinet - Steel with baked enamel finish
Core - Aluminum fins on copper tubes
Fan - Heavy gauge aluminum with steel hub
Motor - Open vented
Fan Guard - Zinc chromate plated steel

AA SERIES

Cabinet - Galvanized steel
Core - Aluminum fins on copper tubes
Fan - Heavy gauge aluminum with steel hub
Motor - Open vented
Fan Guard - Steel with baked enamel finish

AHP SERIES

Cabinet - Steel with baked enamel finish
Core - Aluminum
Fan - Aluminum hub, polypropylene blades
Shroud - Painted steel
Motor - TEFC
Fan Guard - Steel with baked enamel finish

RATINGS

Maximum operating pressure - 250 psig
Maximum operating temperature - 350°F

HOW TO ORDER

- -

MODEL SERIES

AA
UPA
AHP

MODEL SIZE SELECTED

MOTOR

AA SERIES MOTOR OPTION
 -1 = SINGLE PHASE 60 Hz ODP 115 VOLT
 -2A = SINGLE PHASE 60 Hz TEFC 115 VOLT
 -2B = SINGLE PHASE 60 Hz TEFC 208-230 VOLT
 -3A = THREE PHASE 60 Hz TEFC 208-230 VOLT
 -3B = THREE PHASE 60 Hz TEFC 460 VOLT

AHP SERIES MOTOR OPTION

-2 = SINGLE PHASE 60 Hz TEFC 115/208-230 VOLT
 -3 = THREE PHASE 60 Hz TEFC 230/460 VOLT
 -5 = AIR MOTOR

UPA SERIES DIMENSIONS—MODELS UPA-20 & UPA-35

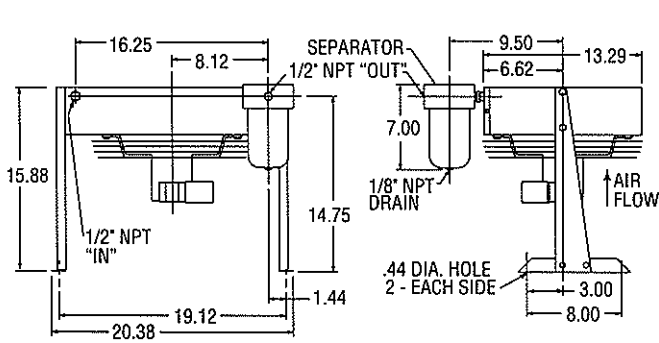

VERTICAL AIR FLOW

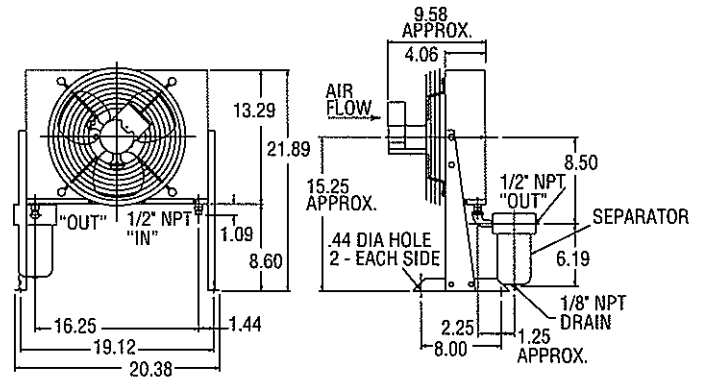

HORIZONTAL AIR FLOW

MODELS UPA-50 & UPA-100

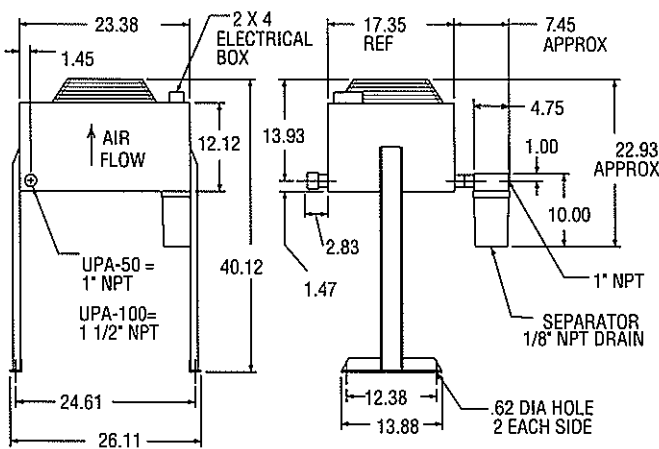

VERTICAL AIR FLOW

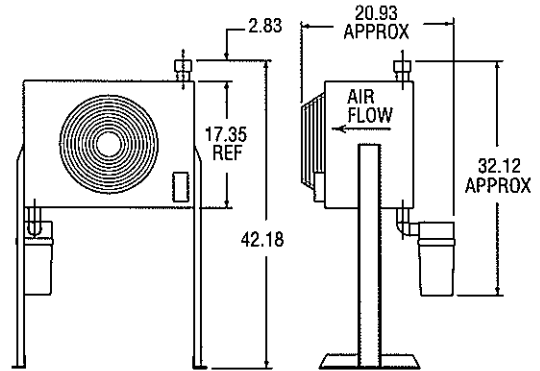

HORIZONTAL AIR FLOW

Note: We reserve the right to make reasonable design changes without notice. All dimensions are in inches.

CAPACITY SELECTION CHART MAX. SCFM @ 5, 10, 15 and 20°F Approach

MODEL NUMBER	INLET TEMP. °F	150				200				250				300				350				RECOMMENDED OPTIONAL SEPARATOR MODEL NUMBER
		5	10	15	20	5	10	15	20	5	10	15	20	5	10	15	20	5	10	15	20	
UPA-20	APPROACH TEMP. °F	17	35*	35*	35*	11	22	35	35*	8	16	20	35	6	12	19	26	5	10	15	21	S-50M or AD
UPA-35		29	43*	43*	43*	17	36	43*	43*	12	27	35	42*	10	20	31	42*	8	16	26	35	
UPA-50		43	72	72*	72*	28	50	70	72*	22	35	50	70	18	32	45	57	15	28	39	50	
UPA-100		95	125*	125*	125*	66	111	125*	125*	52	88	100	125*	44	74	100	125	38	64	86	108	

Above specifications are based on 80 to 125 PSIG operating pressures.
 Maximum pressure drop, less than 3 psi.
 *Maximum ratings restricted by pressure drop, actual thermal capacities are higher.
 A flexible metal hose must be properly installed between the compressor and aftercooler to validate warranty.

ELECTRIC MOTOR & FAN DATA

Model	Fan CFM	Motor H.P.	Voltage	Phase	Full Load Amps	Hz	RPM	Nema Frame	Thermal Overload	Approximate Shipping Weight (Lbs.)
UPA-20	615	1/12	115/230	1	2.4/1.2	60	1550	Custom	Yes	25
UPA-35					2.7/1.4	50	1300			27
UPA-50	945				61					
UPA-100										67

Published electrical ratings are approximate, and may vary because of motor brand. Actual ratings are on motor nameplate.

UPA/AA/AHP
air cooled

AA SERIES

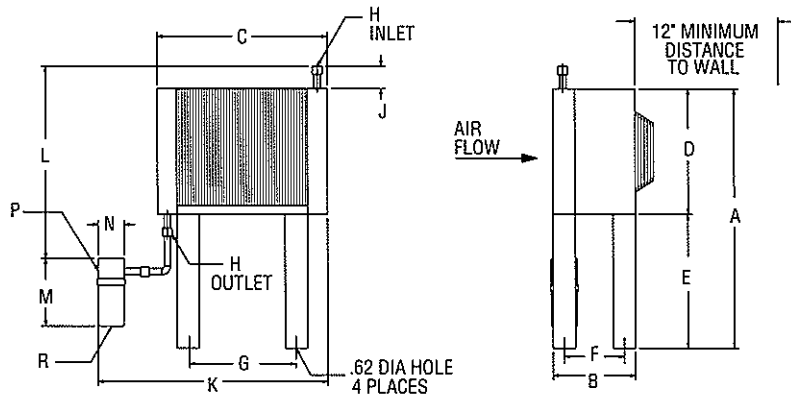

DIMENSIONS

Model	A	B	C	D Approx	E	F	G	H NPT	J	*K Approx	*L Approx	OPTIONAL SEPARATOR				RECOMMENDED OPTIONAL SEPARATOR MODEL NUMBER		
												M	N	P NPT	R			
AA-35	46.50	14.75	30.50	22.50	24.00	10.75	19.09	1.00	4.00	41.12	34.50	10.00	4.62	1	1/4	S-100M or AD		
AA-50								1.50			54.12						35.00	
AA-65																	37.10	
AA-80			43.50					32.09		2.00	54.20						36.60	
AA-100																	58.33	40.60
AA-120																		62.38
AA-150	49.50	47.63	25.50	36.09	12.10	4.70	1 1/2	S-200M										
AA-240	55.50	51.68	31.50													S-300M		

*Dimension will vary depending on the separator model used and the piping between the separator and cooler.
 All Dimensions are in inches.
 Note: We reserve the right to make reasonable design changes without notice.

CAPACITY SELECTION CHART MAX. SCFM @ 5, 10, 15 and 20°F Approach

AFTERCOOLER MODEL NUMBER	INLET TEMP. °F	150				200				250				300				350				RECOMMENDED OPTIONAL SEPARATOR MODEL NUMBER
		APPROACH TEMP. °F	5	10	15	20	5	10	15	20	5	10	15	20	5	10	15	20	5	10	15	
AA-35 AA-50 AA-65 AA-80 AA-100 AA-120 AA-150 AA-240 AA-300	AA-35	25	42	58	73	18	31	43	53	15	25	35	44	13	22	30	37	11	19	26	32	S-100M or AD
	AA-50	34	58	79	99	25	43	59	74	21	36	50	62	18	31	42	52	16	27	38	47	
	AA-65	42	73	99	125	32	55	77	95	27	47	65	81	24	41	57	71	22	37	52	65	
	AA-80	50	87	119	150	40	69	94	117	34	59	80	100	30	52	71	89	28	47	65	82	
	AA-100	60	102	140	177	48	81	112	140	45	73	100	124	38	64	87	110	34	59	81	100	S-200M
	AA-120	81	138	190	235	61	105	142	177	51	87	120	150	43	75	102	127	40	69	94	116	
	AA-150	92	160	220	270	73	125	172	215	63	110	150	187	55	95	130	160	50	86	120	148	
AA-240	160	275	380	425*	120	207	285	355	100	175	240	300	84	145	204	250	78	135	185	231	S-300M	
AA-300	184	318	440	480*	145	250	345	430	125	217	300	375	110	190	257	320	100	175	240	300		

Above specifications are based on 80 to 125 PSIG operating pressures.
 Maximum pressure drop, less than 3 psi.
 *Maximum ratings restricted by pressure drop, actual thermal capacities are higher.
 A flexible metal hose must be properly installed between the compressor and aftercooler to validate warranty.

ELECTRIC MOTOR & FAN DATA

Model	Fan CFM	Motor H.P.	Standard Motor (ODP)		Optional Motor (TEFC)		Optional Motor (TEFC)*		Approximate Shipping Weight (lbs.)
			Voltage	Full Load Amps/Motor	Voltage	Full Load Amps/Motor	Voltage	Full Load Amps/Motor	
AA-35	1375	1/4	115/1/60	7.2	115/208 230/1/60	5/2.6-2.5	208-230/ 460/3/60	1.4-1.3/65	110
AA-50									120
AA-65									140
AA-80									145
AA-100	2450	1/4 (2)	115/1/60	7.2	115/208 230/1/60	5/2.6-2.5	208-230/ 460/3/60	1.4-1.3/65	200
AA-120									200
AA-150									300
AA-240	4600	1/4 (2)	115/1/60	7.2	115/208 230/1/60	5/2.6-2.5	208-230/ 460/3/60	1.4-1.3/65	200
AA-300	4700								300

Standard Motor(s) = 1600 RPM, Custom Frame, Equipped with Thermal Overload. Optional Motor(s) = 1725 RPM, Nema 48 Frame, No Thermal Overload.
 Published electrical ratings are approximate and may vary because of motor brand. Actual ratings are on motor nameplate.
 *3 phase motors available in 50Hz. Reduce performance by 10%.

air cooled
UPA/AA/AHP

AHP SERIES

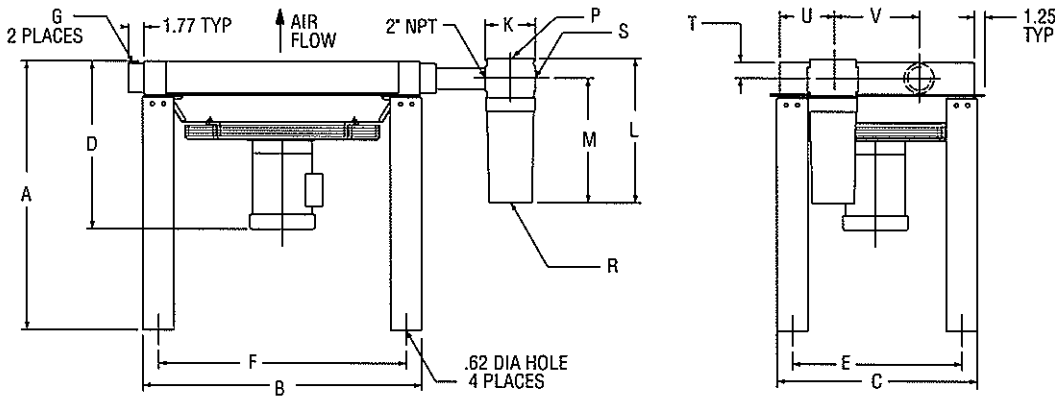

DIMENSIONS

Model	A	B	C	D Approx	E	F	G NPT	OPTIONAL SEPARATOR						T	U	V	RECOMMENDED OPTIONAL SEPARATOR MODEL NUMBER
								K	L	M	P NPT	R NPT	S NPT				
AHP-400	34.20	22.68	17.96	18.01	13.96	18.68	2.00	4.70	18.60	16.00	N/A	.50	2.00	1.85	6.00	4.92	S-600M
AHP-725		30.56	22.37		18.37	26.56										9.34	
AHP-950	36.01	37.24	22.76	22.78	33.24	37.19	3.00	8.00	23.00	20.00	.25	3.00	2.76	8.00	13.76	S-1700M	
AHP-1200		41.19	25.07		25.95										30.89		17.86
AHP-1600		34.89	30.89		30.89										30.89	20.86	
AHP-2000		51.04	37.88		27.57										33.88	47.04	4.00
AHP-2500	49.07	43.70	28.01	39.70	45.07	35.50											
AHP-3000	51.04	52.52	29.17	48.52	47.04	39.28											
AHP-3500		56.30	29.17	52.30	47.04												

All Dimensions are in inches. Note: We reserve the right to make reasonable design changes without notice.

CAPACITY SELECTION CHART MAX. SCFM @ 5, 10, 15 and 20°F Approach

INLET TEMP. °F	150				200				250				300				350				RECOMMENDED OPTIONAL SEPARATOR MODEL NUMBER	
	5	10	15	20	5	10	15	20	5	10	15	20	5	10	15	20	5	10	15	20		
AFTERCOOLER MODEL NUMBER	AHP-400	210	384	520	605	175	375	430	500	160	300	400	464	135	250	340	396	125	235	305	355	S-600M
	AHP-725	355	650	890	1025	308	560	760	880	290	545	725	840	245	450	605	701	225	410	540	625	
	AHP-950	480	871	1178	1360	415	754	1020	1180	390	712	950	1100	320	588	785	910	280	520	690	780	S-1700M
	AHP-1200	600	1090	1475	1710	520	950	1290	1460	490	900	1200	1380	405	735	980	1130	355	650	865	990	
	AHP-1600	790	1440	1950	2260	710	1290	1720	1950	660	1200	1600	1860	530	965	1290	1480	460	840	1135	1300	S-2600M
	AHP-2000	980	1790	2420	2800	870	1580	2140	2460	820	1490	2000	2300	660	1210	1595	1840	572	1040	1400	1610	
	AHP-2500	1220	2220	3000	3470	1090	1980	2680	3100	1035	1880	2500	2870	784	1426	1980	2270	705	1290	1725	1980	
	AHP-3000	1450	2650	3580	4120	1295	2360	3200	3710	1243	2260	3000	3450	985	1794	2360	2715	840	1530	2040	2350	
AHP-3500	1680	3064	4140	4800	1530	2785	3760	4320	1460	2660	3500	4015	1150	2090	2760	3200	950	1740	2350	2700		

Above specifications are based on 80 to 125 PSIG operating pressures. Maximum pressure drop, less than 3 psi. A flexible metal hose must be properly installed between the compressor and aftercooler to validate warranty. In addition, for mobile and other applications where there may be additional stresses to the connections, our 4-bolt SAE Flange should be used. Consult factory for pricing and availability.

ELECTRIC MOTOR & FAN DATA

Model	Fan CFM	Motor H.P.	Voltage	Phase	Full Load Amps 230V	Hz	RPM	Nema Frame	Thermal Overload	Approximate Shipping Weight Lbs.					
AHP-400	2200 1825/2200	1.0	115/208-230 208-230/460	1 3	6.0 3.6/3.2	60 50/60	3450 2850/3450	56C	No	120					
AHP-725	3600 3025/3600	1.5	115/208-230 208-230/460	1 3	8.5 4.8/4.2	60 50/60	3450 2850/3450			170					
AHP-950	4700	1.5	115/208-230 208-230/460	1 3	8.6 4.6	60*	1740	145TC		330					
AHP-1200	7000	5.0	230	1	23.0			184TC		450					
AHP-1600	9700	3.0	208-230/460	3	8.8			182TC		515					
AHP-2000	11000	5.0	208-230/460	3	13.4			184TC		600					
AHP-2500	14000	7.5	230/460	3	19.6	60*	1740	213TC		625					
AHP-3000	17500	10.0						230/460		3	24.8	60*	1740	215TC	645
AHP-3500	17500													750	

All motors shown are TEFC—Other motor options available upon request. Published electrical ratings are approximate, and may vary because of motor brand. Actual ratings are on motor nameplate. Fan motors **must not** be cycled. Outdoor applications must be protected from direct weather. If ductwork or additional static resistance is added to the cooler airstream, an auxiliary air mover may be required. *3 phase motors available in 50Hz. Reduce performance by 10%.

UPA/AA/AHP
air cooled

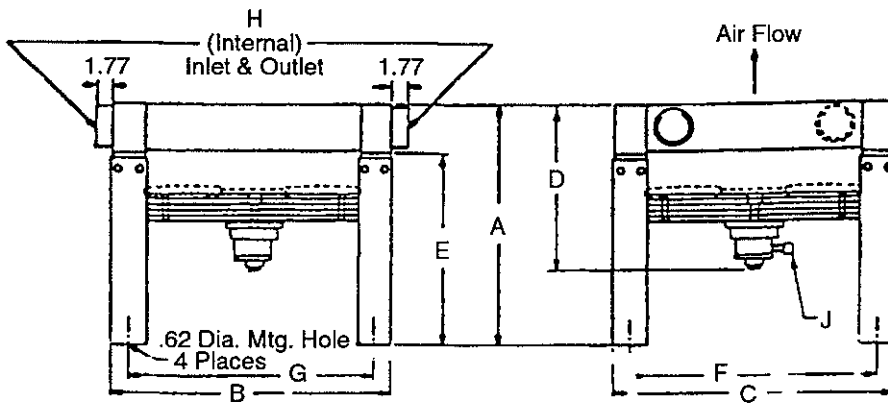

AHP SERIES with AIR MOTOR

Model	A	B	C	D Approx.	E	F	G	H NPT	J NPT	PSI (1)	CFM (2)	Approx. Shipping Wt. (Lbs.)
AHP-400	34.20	22.68	17.96	13.55	30.00	13.96	18.68	2.00	.25	60	50	105
AHP-725		30.56	22.37			18.37	26.56			85	45	140
AHP-950		37.24	26.78			22.78	33.24	60	55	425		
AHP-1200	36.01	41.19	34.89	20.50		30.89	37.19	3.00	.50	70	100	481
AHP-1600		51.04	37.88	33.88		47.04	100			180	595	
AHP-2000		49.07	43.70	39.70		45.07	4.00	1.25	90	230	700	
AHP-2500		51.04	52.52	48.52		47.07			100	275	735	
AHP-3000		56.30	52.52	23.56		48.52	47.07	100	275	795		
AHP-3500			56.30	23.56		52.30	47.07	100	275	825		

Note: We reserve the right to make reasonable design changes without notice. All dimensions are in inches.

1. Air inlet to the air motor must be regulated to this pressure.
2. CFM (Free Air) consumption of the air motor. Lubrication = One drop of oil for every 50-75 CFM of air going through the motor. Use detergent SAE #10 oil. Filter, regulator and lubricators for the air motors are required, but not included.

For more information or to purchase these products, please contact:

**HYDROTHRIFT CORPORATION
(800) 772-0493**

www.hydrothrift.com
sales@hydrothrift.com

air cooled
UPA/AA/AHP