

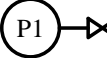

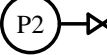

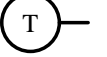

LEGEND

ITEM	DESCRIPTION
	PUMP, CLOSE COUPLED CENTRIFUGAL, TEFC MOTOR
	PRESSURE GAUGE (-30" HG - 30 PSI)
	PRESSURE GAUGE (0 - 160 PSI)
	TEMP GAUGE W/ THERMOWELL (0 - 200 F)
	PTC SENSOR
	FLOW SWITCH
	REDUCER
	BALL VALVE
	BOILER DRAIN, 3/4"
	UNION
	CHECKVALVE
	LIQUID LEVEL SENSOR

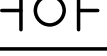
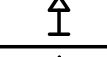
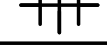

HYDROTHRIFT CORPORATION

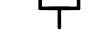
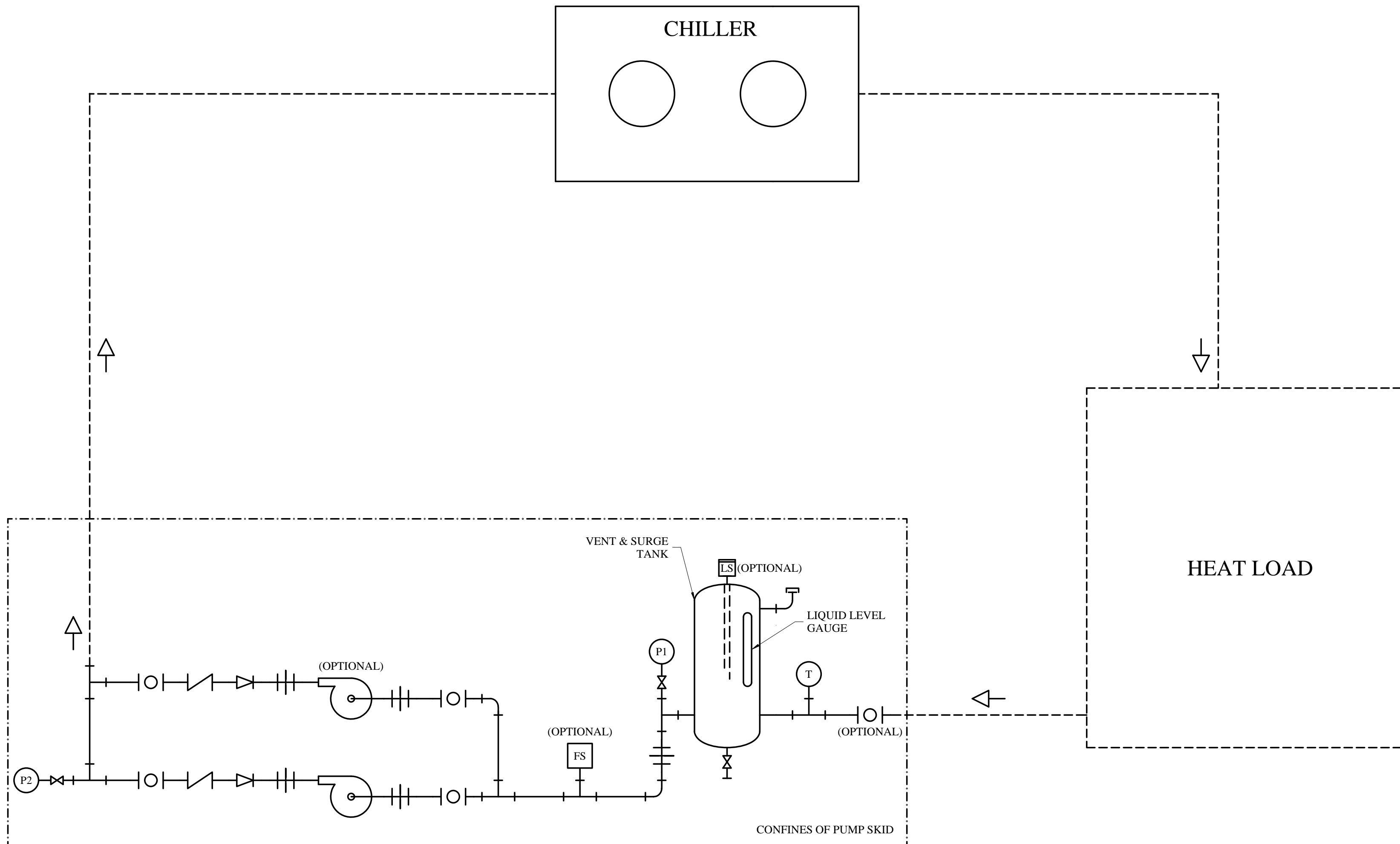
MODEL
CLOSED-LOOP CHILLED-WATER (CW) COOLING SYSTEM

TITLE PIPING & INSTRUMENT DIAGRAM	DRAWING NUMBER PIDSTD-CW	REV. A
--------------------------------------	-----------------------------	-----------